

CL-05 MD DOUBLE SAFETY DOUBLE PINNED DOUBLE WINGED LIFT LANDING DOOR LOCKING DEVICE MOUNTING-ADJUSTMENT-MAINTENANCE GUIDE

First, check if the CL-05 MD Double Safety Double Pinned Double Winged Lift Landing Door Locking Device you have purchased is in the right direction according to your mounting method.

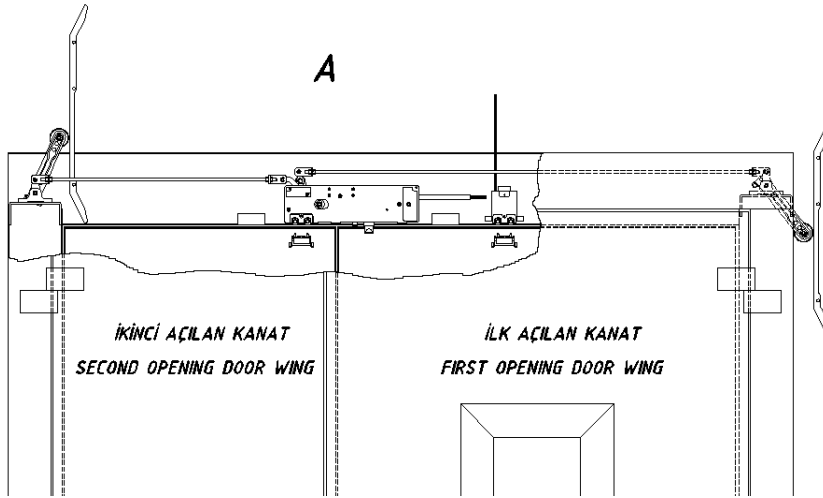

In mounting type **A**, if the first opening door wing is the right wing, the lift landing door locking device to be used is **LEFT**-oriented.

If the other door wing opens first, change the

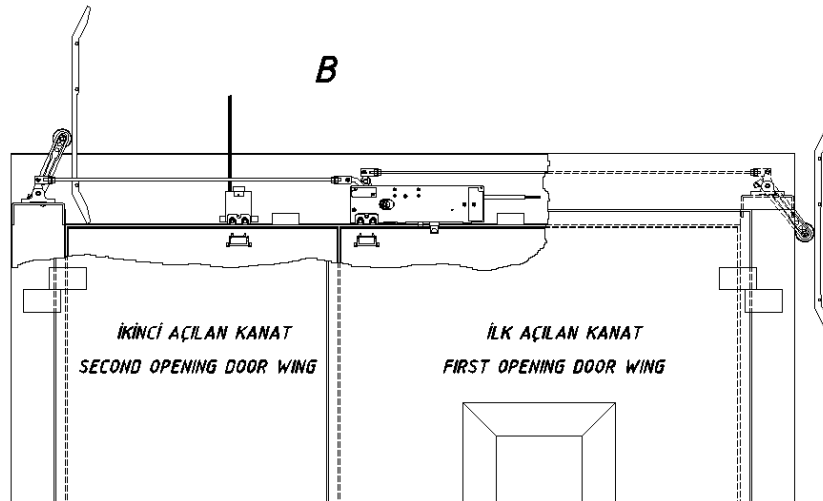

In mounting type **B**, if the first opening door wing is the right wing, the lift landing door locking device to be used is **LEFT**-oriented.

If the other door wing opens first, change the

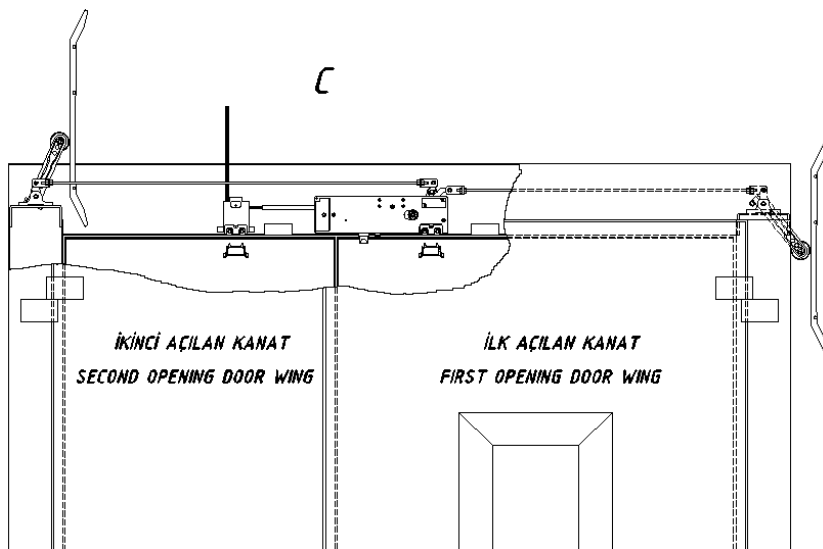

In mounting type **C**, if the first opening door wing is the right wing, the lift landing door locking device to be used is **RIGHT**-oriented.

If the other door wing

If the direction of the CL-05 MD Double Safety Double Pinned Double Winged Lift Landing Door Locking Device is correct depending on the method of mounting, you can proceed with the mounting process.

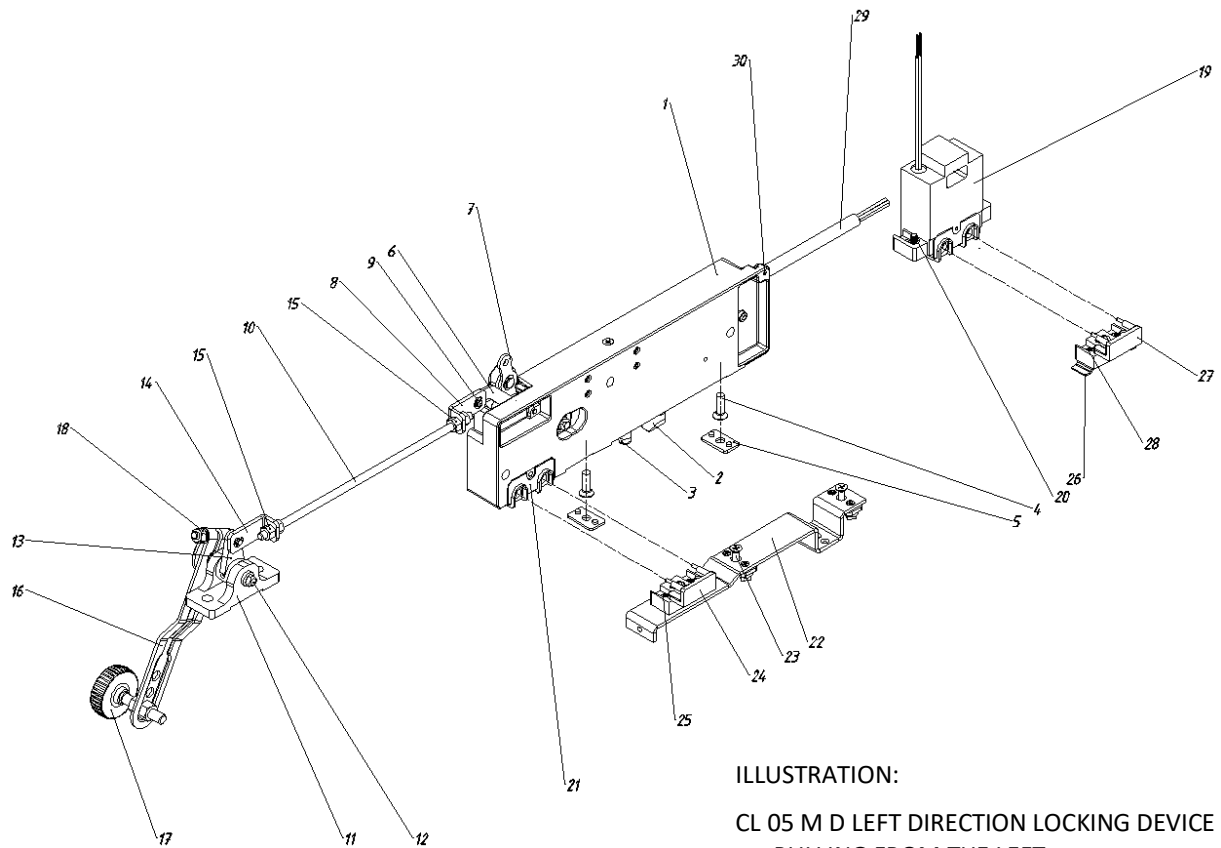

ILLUSTRATION:

CL 05 M D LEFT DIRECTION LOCKING DEVICE
PULLING FROM THE LEFT

MOUNTING –ADJUSTMENT INSTRUCTION

- 1- Remove M6 bolts No. 4 on the surface of the locking device body No. 1.
- 2- Check that there are stiffening plates on the door frame that must be welded into the frame for lock mounting.
- 3- Mount the lock body No. 1 to the door frame using the M6 mounting bolts No. 4 .
- 4- 2nd Safety Pin No. 3 should be placed in a manner so that it releases the latch bolt No. 2 after coming out 2 mm from the hole in the door frame. If necessary, use the door gap adjustment plates of different thicknesses to fulfill this requirement.
- 5- Check the lock's operation after sufficiently tightening the bolts No. 4.
- 6- Mount the unlocking mechanism stand No. 11 on the place prepared for it on the door frame with the help of M8 bolts.
- 7- Connect the joint of lock pull handle No. 8 at the end of the lock pull handle No. 6 extending outside from inside the lock body with the unlocking mechanism joint No. 13 at the end of the unlocking mechanism straight lever No. 13, with the help of M6 threaded rod No. 10 (DIN 975) and four M& bolts No. 15.

(The M6 threaded rod is 1m in length as a standard. If the distance between the lock body No. 1 and the unlocking mechanism stand No. 10 is more than 1 m, then place additional plates in between.)

8- Please note: Adjust the unlocking mechanism straight lever No. 13 towards the top and in a manner so that it oscillates equally on both sides during operation. For this adjustment process, use the nuts No. 15. Adjust by moving the two M6 nuts No. 15 on either side back and forth on the threaded rod No. 10. After the adjustment is completed, tighten the nuts evenly.

NOTE: Even though the installation method shown in the main mounting figure is ideal, the lift landing door retiring cam (lirpomp) used for unlocking is not always on the side of the unlocking lever as shown in the figure.

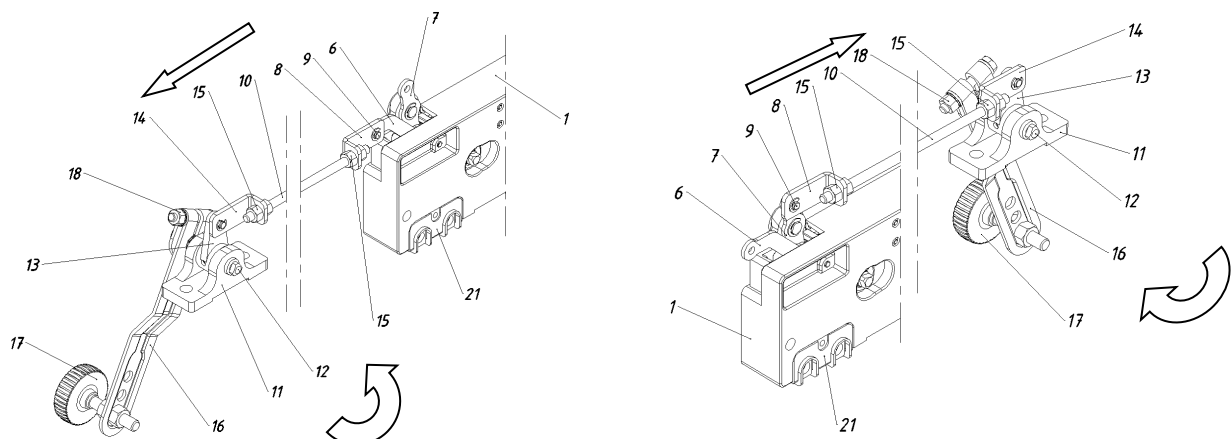

FIGURE 2 (PULL OPERATION)

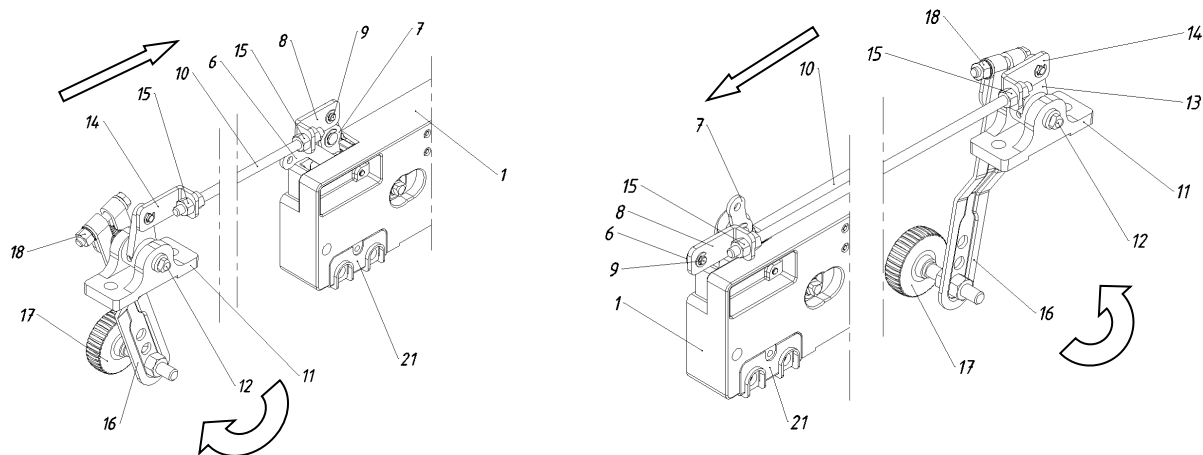

FIGURE 3 (PUSH OPERATION)

In the figures 2 and 3, the mounting and operating logic of the joint parts with the help of a threaded rod is described according to the different lirpomp positions.

In the general mounting drawing, the lock device is operated by lock pull with the help of the unlocking mechanism.

Even if the lirpomp is on the same side, the locking device may have to be operated by pushing due to its mounting method. Accordingly, the figures 2 and 3 will describe the way the joints are connected for pull and push operations.

The figure 2 describes the pull operation;

The lock can be operated by pulling from both sides. This is the recommended way of operation. The threaded rod No. 10, which is used as a joint may not transfer the push force completely as it is bent in very long lengths, and thus may need to be supported. As seen in the main mounting figure, if the lock pull handle joint No. 8 is mounted on the lock pull handle No. 6, it operated by pulling from this direction. **(FIGURE 2)**

If the unlocking mechanism is mounted on the other side of the lock body due to the mounting position of the lirpomp, the lock pull handle joint No. 8 must be mounted on the lock pull reverser handle No. 7. **(FIGURE 2)**

The figure 3 describes the push operation;

As seen in the main mounting figure, if push start is required despite being mounted, the lock pull handle joint No. 8 must be assembled with the lock pull reverser handle No. 7. **(FIGURE 3)**

If the unlocking mechanism is mounted on the other side of the lock body due to the mounting position of the lirpomp, the lock pull handle joint No. 8 must be mounted on the lock pull handle No. 6. Thus, the system can be operated by pushing. **(FIGURE 3)**

In order to be able to make a relocation between the lock pull handle No. 6 and the lock-pull reverser handle No.7 of the lock pull handle joint No. 8, remove the pin and the clip No. 9. Change the handle and reattach the pin and clip to complete the process. During replacement, store them safely as pin and clip are tiny parts.

9- Attach the unlocking lever No. 16 to the knurled part of the mechanism draw lever shaft No. 12, with the unlocking lever roller No. 17 is positioned outside.

10- Tighten the unlocking lever clamping bolt No. 18 by adjusting the unlocking lever No. 16 according to the operating position of the lirpomp.

11- Remove the mounting bolts and nuts of the M5 2nd plug contact counter contact group No. 20 from the 2nd plug contact counter contact group No. 19.

12- Place the 2nd plug contact counter contact group No. 19 in the place prepared for it in the door frame, and mount the M5 2nd plug contact counter contact group No. 19 with the help of mounting bolts and M5 nuts.

13- The assembly of the plug contact No. 24 can be done with the help of the plug contact door mounting plate No. 22.

Remove the M5 bolts No. 23 from the plug contact door mounting plate No. 25.

After aligning the plug contact door mounting plate No. 22 to the mounting place on the door wing, mount it with the help of bolts No. 23. Tighten the bolts when the plug contact No. 24 contact is adjusted to approximately coincide with the 1st plug contact counter contact group No. 21.

14- Make fine adjustment on the 1st plug contact group No. 24 by using the adjustment bolts No. 25.

15- Loosen the locking bolt No. 31 shown in the figure no. 4 in order to adjust the axis of the plug contact No. 22 back and forth. Then, make an adjustment using the pin on the plug contact group No. 32 and fasten it again by tightening the fixing bolt No. 31.

**** Bolt No. 31 must be loosened while adjusting back and forth and must be tightened again after adjustment.**

16- Mount the 2nd plug contact group No. 27 on the other door wing and facing opposite the 2nd plug contact counter contact group No. 19, with the help of the 2nd plug contact bridge part No. 26.

17- Make fine adjustment by using the 2nd plug contact group adjustment bolts No. 27.

18- You can make the back and forth adjustment of the 2nd plug contact counter contact group No. 19 in the same way as described in item 15. Do not forget to tighten the fixing bolt after adjustment.

19- Cabling for electrical connection will be made in two groups.

Set the electrical cable connections for the lock body as follows.

The plug contact is shown on the lock glass cover; the location of the plug contact counter contact group is shown with the letter **A** and the location of the internal safety contact is shown with the letter **B**.

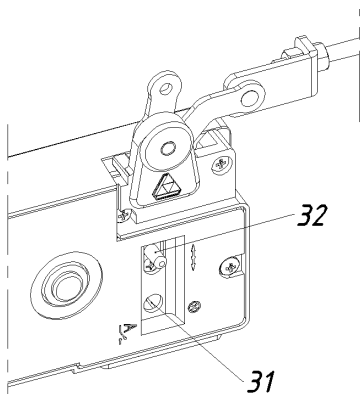

FIGURE 4

Connect the plug contact counter contact group cables coming from the panel to the black-color cables inside the cable protecting hose No. 29 with the help of a connector.

Connect the inner safety contact group cables coming from the panel to the white cables inside the cable protecting hose No. 29 with the help of a connector.

Connect the grounding cable to the body with the help of the grounding bolt No 30 shown in the picture.

Make the electrical connection of the 2nd plug contact counter contact group No. 19 with the help of a connector to its own cables coming from the panel.

IMPORTANT NOTE

In order to deactivate the PRE-BLOCKING safety system used in the CL-05 MD Double Safety Double Pinned Double Winged Lift Landing Door Locking Device, the 2nd Safety Pin No. 3 should protrude 2 mm from its hole in the frame. Only after it is achieved, the locking system switches to the locking process. If the hole in the 2nd Safety Pin No. 3 is blocked for an undesired reason, the lock blocks itself and does not work. (If the diameter of the hole prepared for the exit of the 2nd Safety Pin is small, enlarge the hole with a Ø11 drill.)

A pre-blocking safety system has been developed with a minimum gap of 2.5 mm between the door frame and door wing. If the gap is less than this value, it would not be possible to activate or deactivate the pre-safety system and the lock would block itself.

When the gap between the door frame and the door wing is less than 2.5 mm, pull the lock back inside the frame by using the black-color door gap adjustment plates No. 5 placed in the bags inside the lock box. In this way, you can activate the CL-05 MD Double Safety Double Pinned Double Winged Lift Landing Door Locking Device.

Door gap adjustment plates No. 5 are manufactured in different thicknesses. You can pull the lock back by using these plates between the lock front surface and the stiffening plate.

The pin protrusions on the plates will be inserted into the holes on the mounting surface of the lock body. Since the thicknesses of the plates are different, use the plates with a sufficient thickness.

MAINTENANCE INSTRUCTION

- 1- Liquid oils should be used instead of solid oils during monthly routine maintenance of lifts, since solid oils accumulate dust and dirt on the working parts.
- 2- Check the healthy working conditions when carrying out the monthly routine maintenance as described during the mounting.
- 3- Do not execute any non-recommended interventions.
- 4- Never disassemble inside of the lock even for repair and maintenance purposes.
- 5- During the general maintenance, if the lift door is required to be painted, lock must be dismantled and then mounted on its original place after the painting is completed. Paint residues that entering into the working parts can lead to problems of operation of the lock. Paint removers can damage plastic parts.
- 6- If situations that prevent the conductance of working contacts are detected during monthly routine controls, apply proper cleaning to eliminate unfavorable conditions. If the contacts are required to be replaced, please contact our company.